



We've made a handy video version of this fitting guide, just click the play button to view it.

If you prefer to print the instructions or simply to follow step-by-step, just keep reading.

## Fitting the brackets

1

The brackets offer two methods of installation:

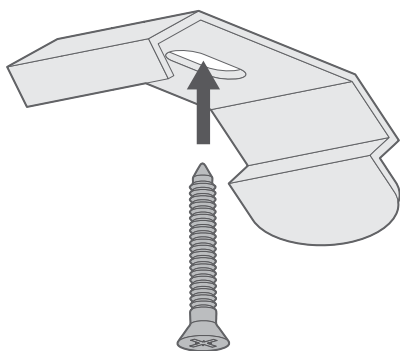

**Top-Fixing**

Use the single hole in the top of the bracket to fix to the lintel (the 'ceiling' of the recess). The protruding tab on the bracket should be closest to the window

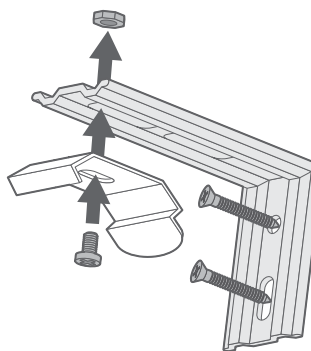

**Face-Fixing**

Join the bracket to the 'L' shaped face-fixing plate. Use two screws through the back plate to mount onto a facing surface (a wall or window frame)

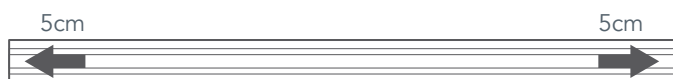

Note that the position of the outermost brackets should be at least 5cm away from the ends of the rail, with any other brackets evenly distributed across the width.

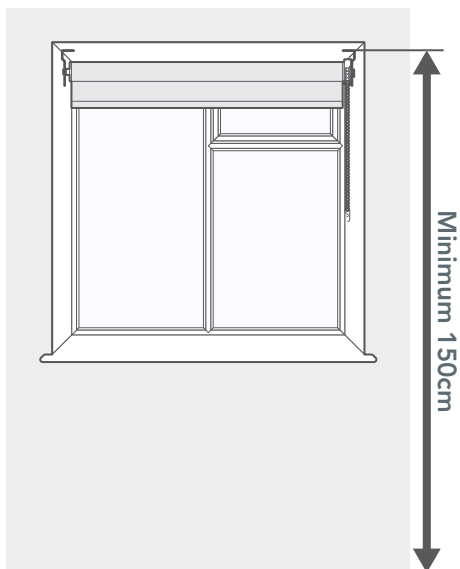

For safety reasons, always ensure that the top of the blind is installed at least 150cm (1500mm) from the floor.

**Fitting the blind**

**2**

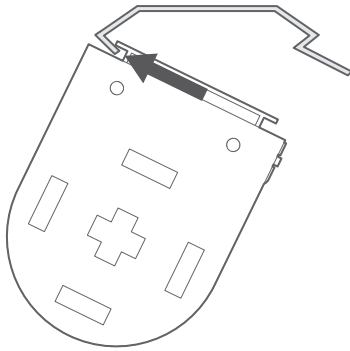

Situate the front lip of the headrail into the front of the bracket.

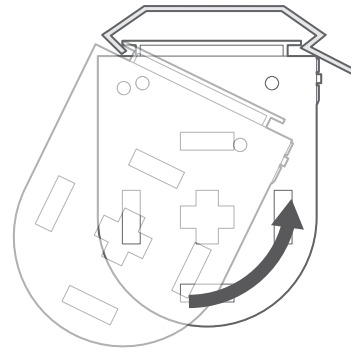

Push the back of the headrail upwards to lock it into the back of the bracket.

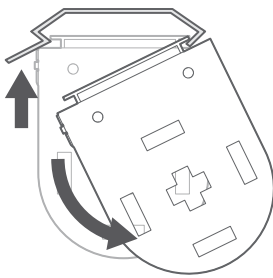

To release the blind from the brackets at any point after installing, push up firmly against the tab protruding from the back of the bracket. At the same time, twist the back of the headrail downwards to disengage it at the back.

**Cord Tensioner**

**Child Safety**

**3**

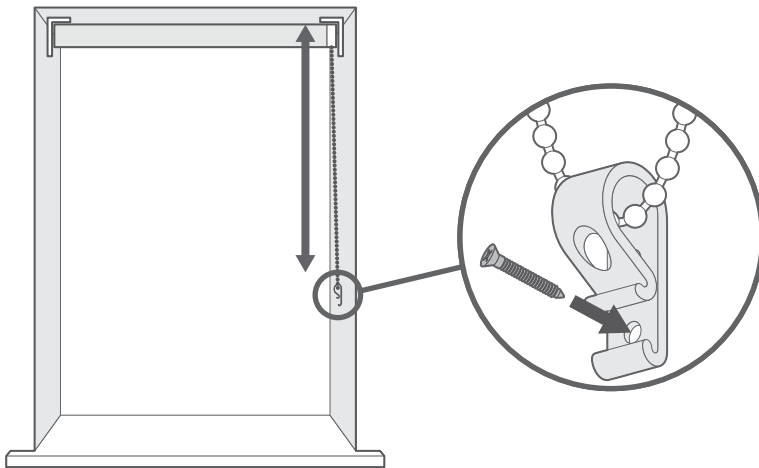

The cord retaining device must be installed at the maximum distance possible from the control mechanism to prevent looped cords from becoming slack.

Place the retaining device on the wall and mark the position of the screw hole(s) with a pencil.

Attach the retaining device to the wall using the fixings provided.



Young children can be strangled by loops in pull cords, chains, tapes and inner cords that operate the product.

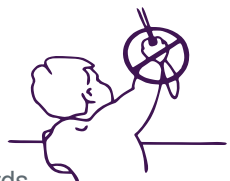

To avoid strangulation and entanglement, keep cords out of the reach of young children. Cords may become wrapped around a child's neck.

Move beds, cots and furniture away from window covering cords.

Do not tie cords together. Make sure cords do not twist and create a loop.